

INSTALLATION INSTRUCTIONS

FOR

AIR CONDITIONING CAT D5H

MODEL SEQUENCES: 8RC, 7NC, 1DD, 9HC, 3MD, 1YD, 4KD, 2SD, 8RJ

HAMMOND AIR CONDITIONING LTD
INGERSOLL, ONT, CANADA
1-800-267-2665

EVAPORATOR COIL: The evaporator coil mounts in front of the heater coil directly ahead of the cab windshield.

1. To access, remove the filter intake cover and the air filter coil and A/C hose knockouts. Loosen the two bolts that hold the heater coil in.
2. Insert the evaporator core into the area in front of the heater coil. Line the slots on the mounting flanges on the evaporator coil up with the two bolts that held the heater coil in place.
3. Tighten down the heater bolts to clamp the evaporator into position.
4. Seal any air gaps around the top or sides of the coil.
5. Leave covers off until the thermostat has been installed and the system has been tested for leaks.



Evaporator in place alongside heater coil.



Top of evaporator assembly in heater box.



Evaporator assembly showing hoses.



Evaporator cover in place with thermostat.

THERMOSTAT: The thermostat mounts in the factory position on the front dashboard.

1. Open the control panel in front of the operator's position to access the wiring and set-up locations for the thermostat.
2. Locate the factory position for the thermostat (see photograph) and cut out the covering over the mounting hole. Make sure the thermostat has the backing nut in place before installing. Insert the thermostat into the hole. Tighten down the securing nut and install "Temp" knob.
3. Run thermostat probe out of the cab (through the factory knockout) into the evaporator coil area. Insert the probe into the evaporator coil about 6".



Thermostat in location on dash control panel.

RECEIVER DRYER: The receiver drier is mounted at the back of the engine compartment below the evaporator area.

1. Mount the dryer in the position indicated in the installation pictures with the hardware provided.
2. Secure the dryer to the mount using the large gear clamps provided. Ensure that the inlet side of the dryer points towards the radiator.



Drier in place.

COMPRESSOR :

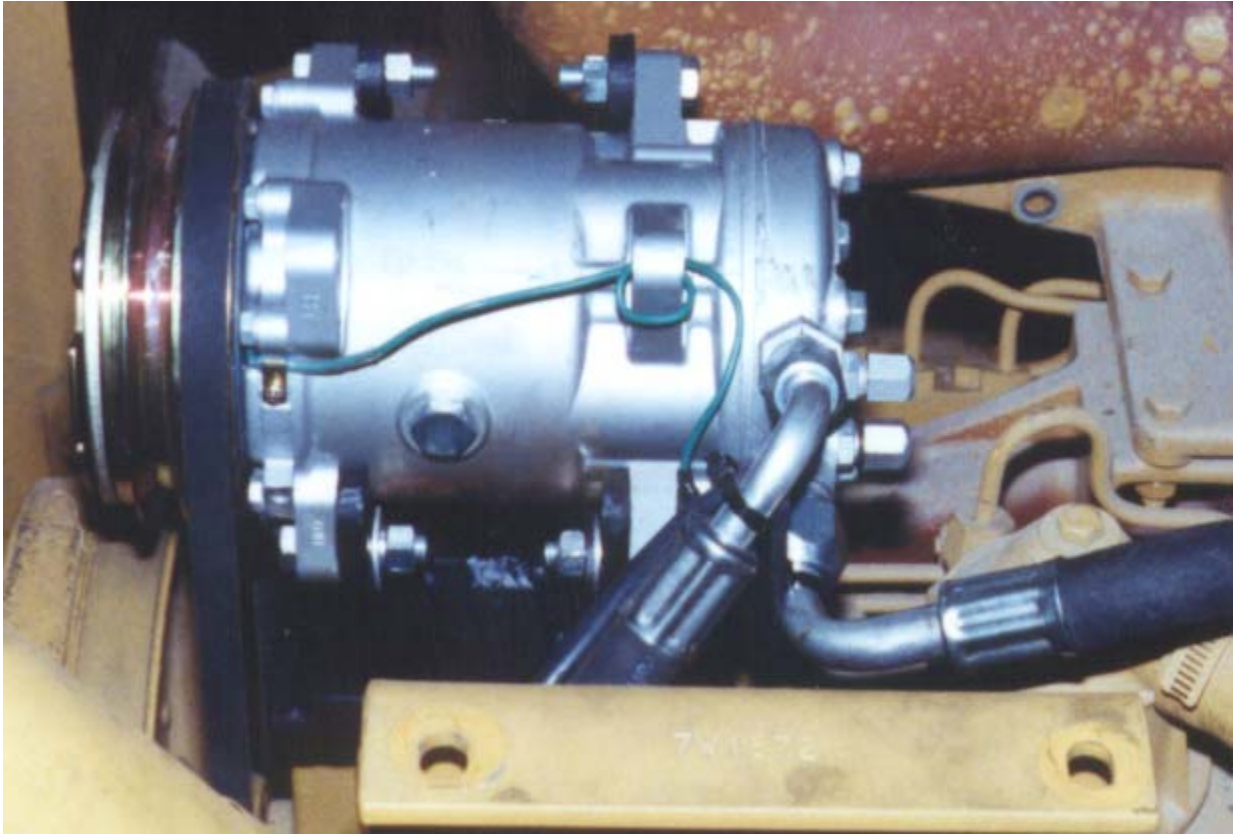

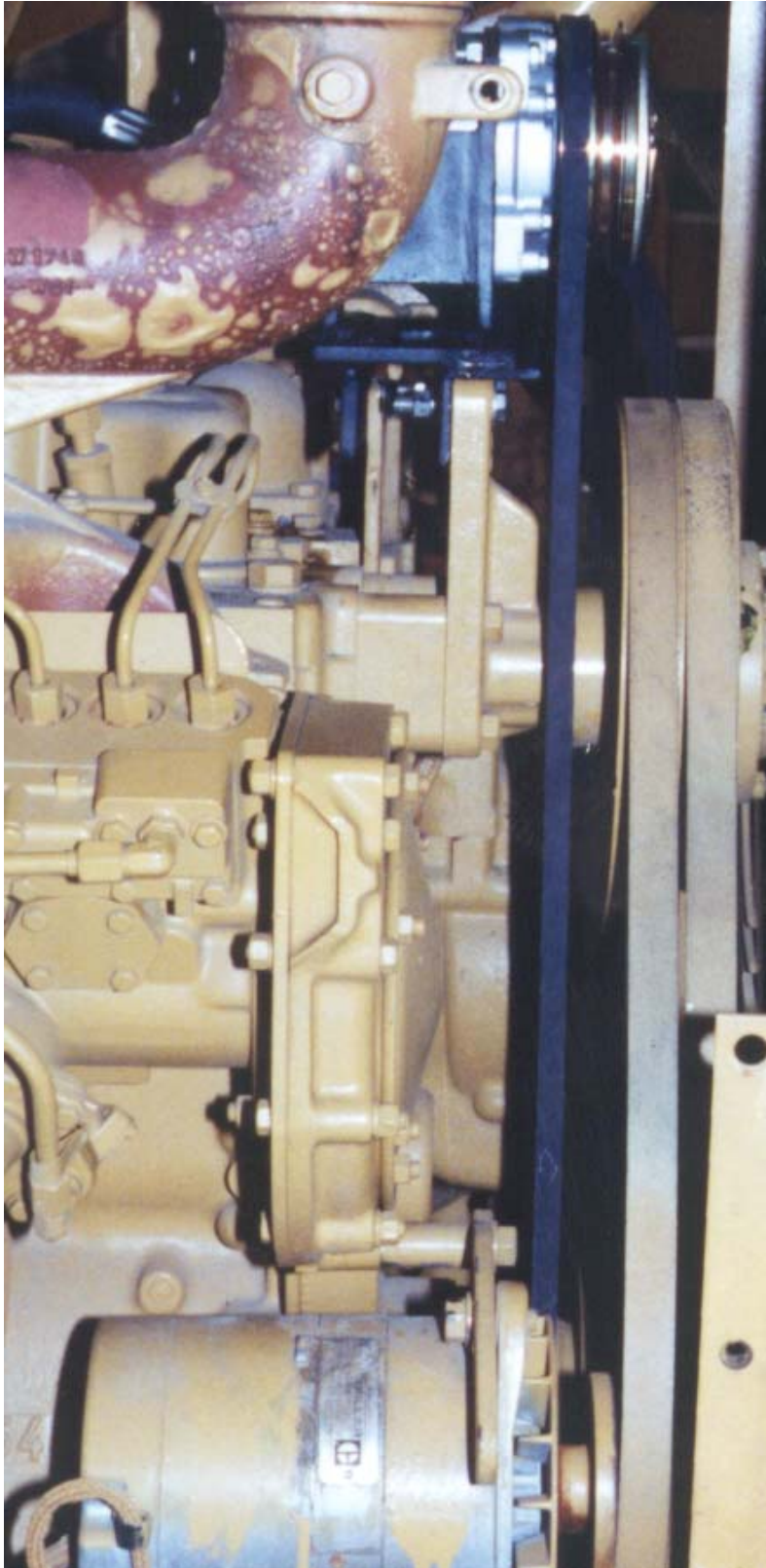



CONDENSER :

The electric heavy duty condenser set-up supplied can be bolted directly to the roof of the cab or it can be hung off the back of the cab using the "Z" mount bracket setup.

Direct Mount

1. Place the condenser on the roof in the desired location with the fans towards the rear of the machine. Mark the six mount holes.
2. Remove the headliner from the inside of the cab. Drill the six mount holes for 3/8" bolts.
3. Apply a bead of silicone around each hole.
4. Set the condenser in place over the holes and bolt it down.
5. Put the bolts up through from the inside with a fender washer on the inside surface of the roof.



"Z" Bracket Mount :

1. Place the "Z" bracket on the back of the cab so the upper section of the "Z" bracket rest on the top of the roof and rest hangs down over the rear window. Mark the six mounting holes.
2. Remove the headliner from the inside of the cab.
3. If any of the mount holes are not going to be accessible from inside the cab, they must be drilled and tapped for a 3/8" coarse thread bolts.
4. Apply a bead of silicon around each hole. Set the "Z" bracket down over the holes and bolt in place. Put the bolts up through from the inside the cab with a fender washer on the inside surface of the cab.
5. Once the "Z" bracket is secured to the roof, the heavy duty electric condenser can be placed on the brackets and bolted down.

ELECTRICAL:

The wiring set-up used in this system is designed to be very straightforward to install and understand.

1. Tap into the yellow wire #521 coming off the factory blower switch. This should be live whenever the blower switch is turned to the A?C side of the blower switch. Use a 14 gauge red wire for this.
2. Run the 14 gauge red wire along with two 14 gauge black wires for the thermostat and the thermostat probe out to the heater box through the existing ½" knock out in the top of the heater box.
3. Run the three wires in loom down and out of the heater box along with the A?C hoses. Just outside the box, split one black 14 gauge wire out of the loom and run up to the compressor and pressure switch. Route the other two wires down under the floor of the cab towards the rear of the machine. Bring them up from under the cab on the left side of the bulldozer into the electrical box area.
4. Mount the circuit breaker and relay close the electrical box. Draw main power off the ignition live side of the main relay and run it through the circuit breaker and then to the relay.
5. Connect the 14 gauge red wire from the blower switch to the control circuit on the relay. Connect the other side of the control circuit to ground.
6. From the main power outlet on the relay connect, the 14 gauge black thermostat wire and the condenser power wire together. Do this by putting both wires into one yellow female QDT and plugging it into the relay.

CAT D6H ELECTRICAL

FRONT CONTROL PANEL

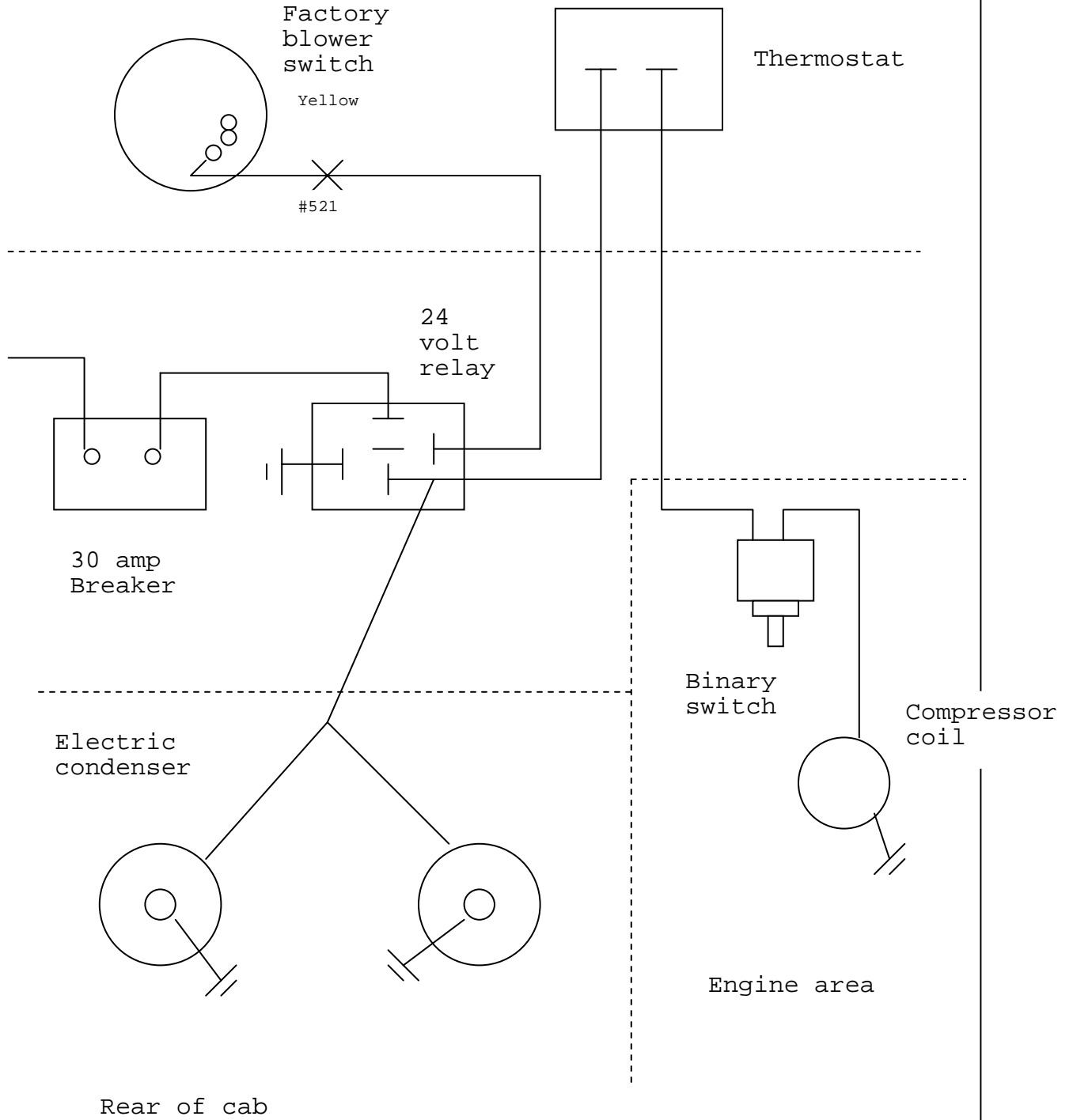

5/16" hose drier to expansion valve:

Connect the straight fitting to the expansion valve and run it straight down out of the heater box. Route it back to the electric condenser along with the 13/32" hose. Connect the 90o 5/16 fitting to the outlet of the drier mounted on the side of the condenser box.

13/32" hose compressor to condenser:

Connect the 90o fitting with the 134a charging port up to the rotolock fitting on the discharge side of the compressor. Route the hose down to the frame and then back with the 1/2" hose toward the evaporator. At the heater box, route the hose back down under the cab and then up to the rear of the electrical compartment area. Bring the hose up and out beside the left hand R.O.P.S. post and then up the inside of the R.O.P.S. post to the 13/32 fitting on the electric condenser.

1/2" Suction hose compressor to evaporator:

Connect the 90o fitting with the 134a charging port up to the rotolock fitting on the suction side of the compressor. Route the hose down to the frame (with the 13/32" hose) and back along with the 5/16" hose to the evaporator assembly. Route the hose through the cap and connect to the outlet side of the evaporator.



Hoses into evaporator box with clutch wire in background.

IMPORTANT: Make sure "O" rings are used on all fittings. Use refrigeration oil on all "O" rings to achieve a proper seal.

Refrigerant Flow Pattern in a Standard Air Conditioning System

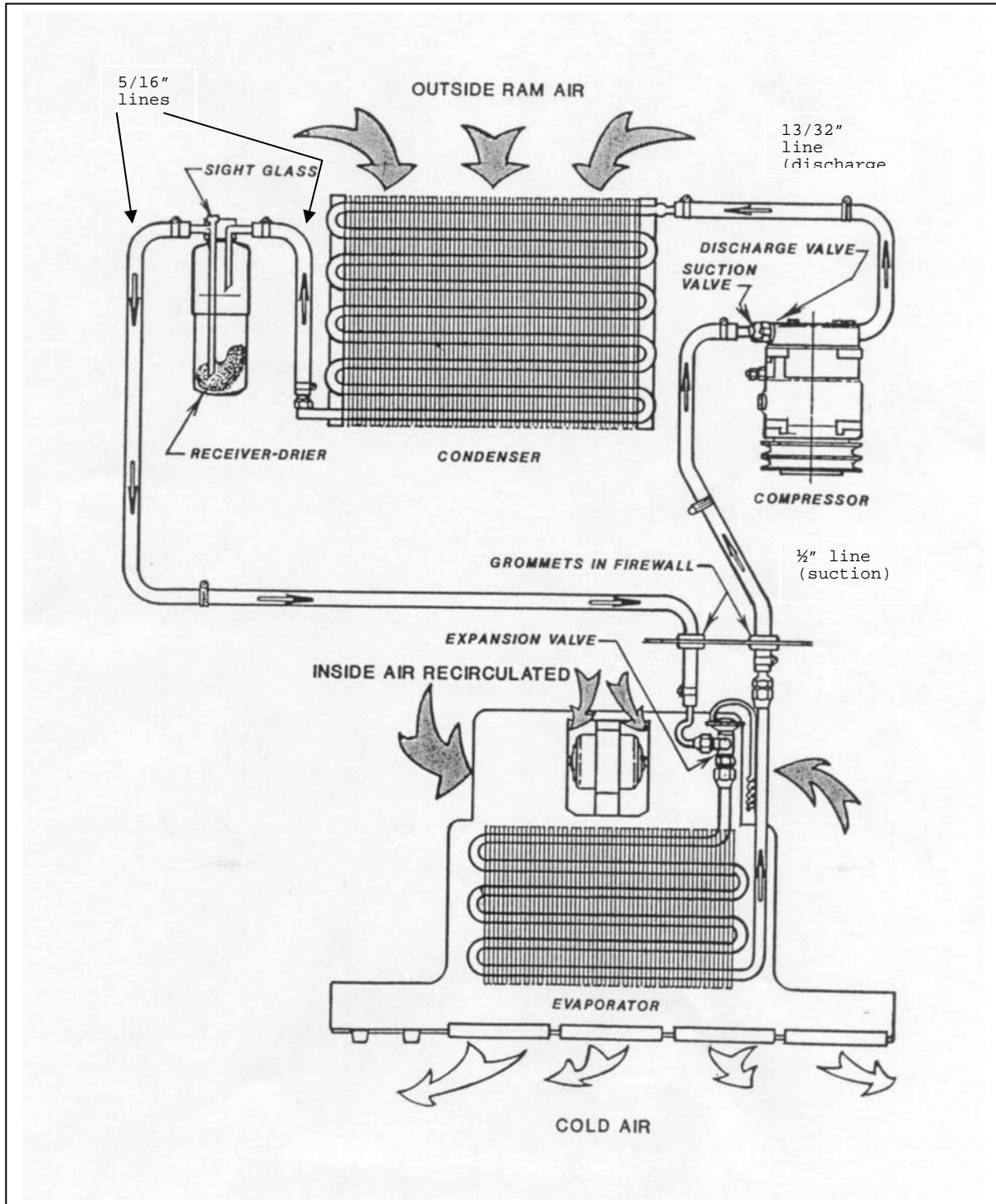

Thermostat Setting Procedures

- 1) Thermostat types
 - a) preset
 - b) adjustable
 - a) A preset thermostat is adjusted to its specific cut in and cut out temperatures when manufactured and does not have a rotary adjustment for the operator.
 - b) An adjustable or rotary thermostat has been manufactured to a predetermined cut in and cut out temperatures, but it is also operator adjustable to achieve the desired comfort level.

Both types of thermostats can have their factory settings adjusted by turning the setting screws on the body of the thermostat. One body type has the setting screws mounted externally and labeled for direction of rotation. The other body type requires the removal of the plastic end plate to expose the set screw.

- 2) Thermostat probe location: The location of the thermostat probe in an evaporator coil can be very important to achieve the maximum cooling potential of the coil while also preventing coil freeze-up. There is no set location for the thermostat probe to be put that will be optimum for all systems, but several rules of thumb may be followed:
 - a) Insert the probe in the coldest area of the evaporator coil.
 - b) Insert the probe from the top of the coil down, if possible.
 - c) Make sure that at least the last 3" of the thermostat probe are in the coil.

To find the most likely area where the coil is the coldest, consider these factors:

- 1) Direction of air flow through the coil.
 - 2) The coil area likely to have the lowest air flow.
 - 3) The inlet locations of the refrigerant into the coil.
 - 4) The inlet of the hotter outside air into the coil area.
-
- 1) Usually the coldest side of the evaporator coil will be the air outlet side. Often the thermostat probe can be inserted between the last and second last row of tubes.
 - 2) The lower air flow area of the evaporator coil in most systems tends to be near either end of the coil. These areas will be colder
 - 3) The area of the coil that the refrigerant inlet tube(s) occupy should be the coldest part of the coil.
 - 4) If the system is equipped with an outside air intake, where

and how that air is brought into the evaporator area can have a large effect on the coil temperature. If all the outside air is piped into the evaporator in one area, that area will be considerably warmer in hot weather.

By looking at all these different factors, the area of an evaporator coil most likely to be the coldest can be determined.

Once the probe is inserted, the A/C system needs to be tested. Run the system to ensure that the thermostat is cycling the compressor off at the appropriate temperature. A core temperature ranging between 25° and 30° F should cause the thermostat to cycle off. The air temperature at the vent outlet closest to the evaporator coil should be between 38° F and 45° F when the compressor cycles off.

If the thermostat doesn't cycle off after a reasonable cool down period, and the air outlet temperature has dropped below 40° F, the cut in and cut out settings should be adjusted until the compressor is cycling on and off regularly. Let the system run for a decent time period (at least 15 min) and then check the evaporator coil for any signs of freezing.

Aeroquip E-Z Clip Assembly Instructions

Step 1. Cut the hose to proper length with an appropriate cutting tool. Aeroquip's hand held hose cutter has been specially designed for cutting all non-wire reinforced hose, such as GH-134 Multi-Refrigerant hose. Be sure the cut is made square to the hose length.

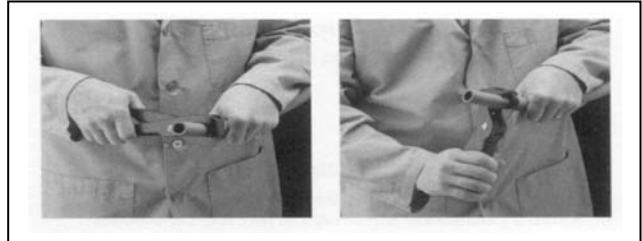

Step 2. Install two proper-sized clips onto the cut end of the hose. Orientation of the clips does not affect the performance of the connection. However, for ease of assembly, both clips should have the same orientation.

NOTE: Failure to slide the clips over the hose at this time will require the clips to be stretched over the hose or fitting later. This may permanently damage the clip.

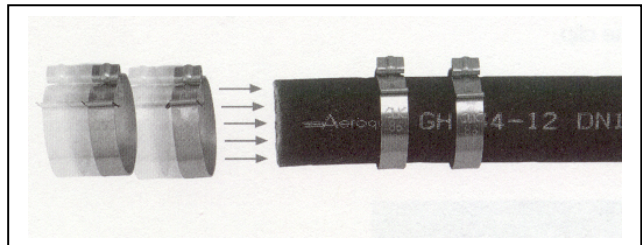

Step 3. Lubricate the nipple with a generous amount of the refrigeration or A/C system's compressor lubricating oil. This MUST be done to lower the force of nipple insertion.

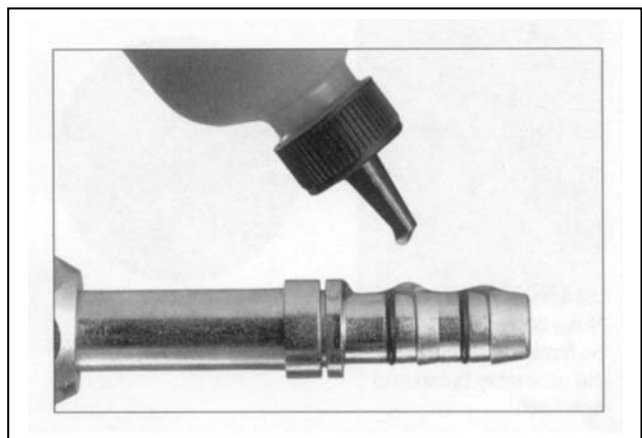

Step 4. Insert the nipple into the hose. To ensure that the nipple is fully inserted, check the gap between the cut end of the hose and the shoulder on the nipple. Care should be taken to avoid kinking or other damage to the hose during nipple insertion.



NOTE: Be sure to wipe excess oil from the nipple and hose.

Step 5. Snap the cage into the groove on the nipple. The arms should extend over the hose length. When the cage has been correctly installed in the cage groove, the cage will be able to rotate in the groove. This step MUST be performed to ensure:

1. The clips will be located over the O-rings on the nipple.
2. The connection will be compatible with the connection's pressure rating.

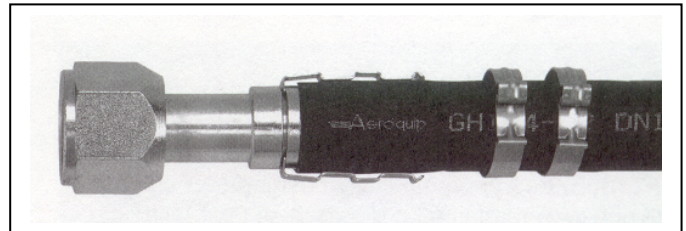
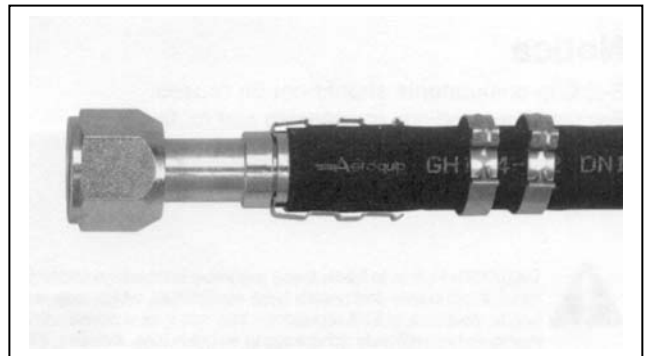

Step 6. Slide the clips over the cage arms and into the channels on each arm.

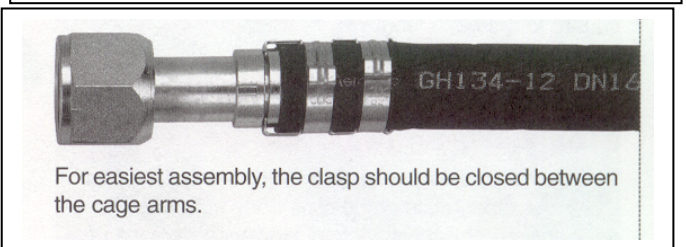

Step 7. Use the pliers to close the clips. The pliers should be positioned squarely on the clip connection points and should remain square during the closing of the clip.

NOTICE: E-Z Clip components should not be reused.

